

TTC

TraceTek Sensing Module with Relay Contacts

The TraceTek TTC module offers a low cost option for liquid leak detection. It is designed for use with any TraceTek sensing cable, and can be integrated into a variety of monitoring systems. The TTC module includes three sets of relay contacts which can be used for remote annunciation and equipment control. A remote annunciation device is available.

Easy setup

All field wiring connections are easily made to a terminal strip molded into the base of the module. The module can be installed to reset automatically when the sensing cable dries following a leak, or to require a manual reset using the button provided. The TTC module includes adjustments for sensitivity to leaks, and

for the time delay before the leak alarm relay trips. These adjustments can be made in the field.

Versatile design

The TTC module provides separate relays for leak alarms and trouble alarms. The Leak relay has two sets of contacts so it can be used both to annunciate the alarm, and to provide direct control linkage to local devices. However, the system is not designed for constant switching applications. The Cable Break alarm monitors the integrity of sensing cable and jumper cable, and will trip if continuity is lost. This trouble relay is normally energized, so it will also signal if there is a loss of power.

The TTC module may be installed in non-hazardous indoor locations. Its small size allows for mounting in or on walls, or on DIN 1 rail systems.

Applications

The TTC is ideally suited to be simply integrated into centralized monitoring systems for large facilities. Typical applications include monitoring for leaks from individual pieces of equipment such as air-handling units, water-cooled machinery, single tanks, pumps, sumps, or other locations where a single length of TraceTek sensing cable is used.

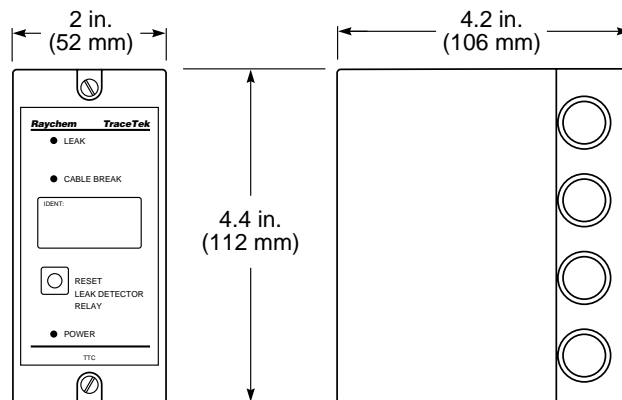
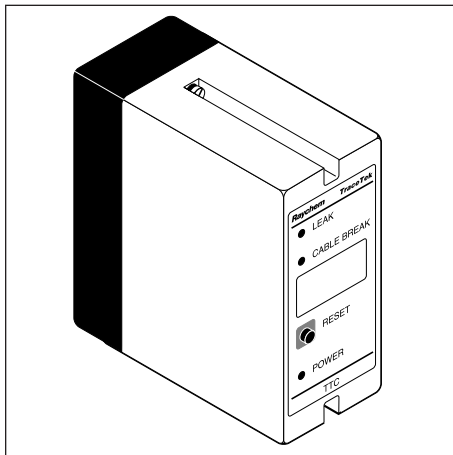

Technical Information

Sensing cable compatibility	All TraceTek sensing cables	
Max length of sensing cable (per channel)	100 ft (30 m)	
Temperature rating	32°F to 122°F (0°C to 50°C)	
Plastic enclosure	NEMA 1, IP 20	
Weight	0.77 lbs (0.35 kg)	
Power supply requirement (transformer not included)	12 to 24 Vac; 50/60 Hz	250 mA
	15 to 24 Vdc	150 mA
Terminal block wiring	14 AWG (max. 2.5 mm ²)	
TraceTek jumper cable wiring	18 AWG (4 x 1 mm ²)	
Relays	Leak	1 DPDT, Form C 5 A rating at 30 Vdc or 250 Vac
	Trouble	1 SPDT, Form C 5 A rating at 30 Vdc or 120 Vac Normally energized

Ordering Information

Catalog Number	Description
TTC-1	TTC alarm module with relay contacts
Accessories: TTE-XAL	External audible alarm
TTC-DRC	DIN 1 rail mounting clip

TTC TraceTek Sensing Module with Relay Contacts

Module Functions

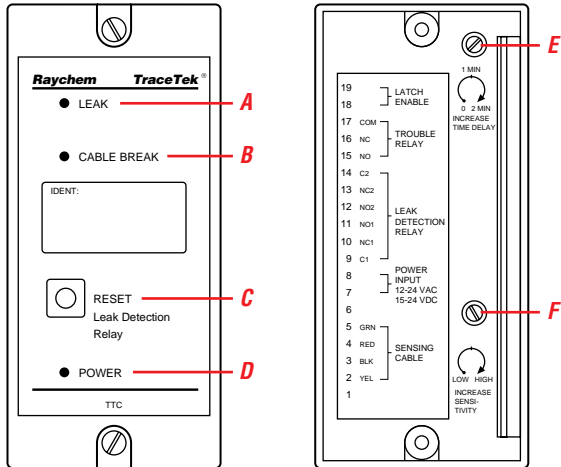

- A LEAK indicator (red LED)**
Indicates system has detected a liquid leak.
- B CABLE BREAK indicator (yellow LED)**
Indicates system has detected a break in the sensing cable.
- C RESET switch and indicator (red LED)**
Indicates leak relay has been activated. Push to reset manually.
- D POWER monitor (green LED)**
Indicates the system is on.
- E Adjusts time delay (0-2 minutes).**
- F Adjusts sensitivity.**

Terminal Block Wiring

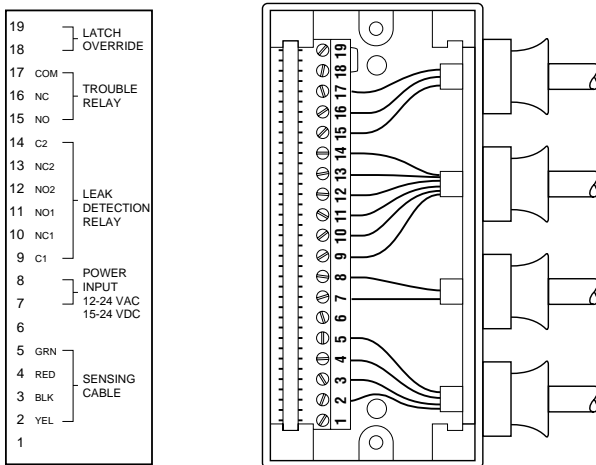

Typical configuration

- 18 – 19 Latch enable (Jumper enables alarm relay to latch.)*
- 15 – 17 Trouble relay (SPDT)
- 9 – 14 Leak alarm relay (DPDT)
- 7 – 8 Power input, 12-24 volts AC or 15-24 volts DC
- 6 Open (Do not use.)
- 2 – 5 Sensing cable (2-yellow, 3-black, 4-red, 5-green)
- 1 Open (Do not use.)

*Note: If jumper is removed, leak relay automatically resets when sensing cable dries

Approval Information



The TTC module is UL Listed and CSA Certified for use in ordinary areas.



The TraceTek products group is a part of Raychem Chemelex Division. Chemelex Division is ISO 9001 certified.

Raychem Corporation
Commercial & Industrial
Infrastructure Division
 300 Constitution Drive
 Menlo Park, CA 94025-1164
 Tel (800) 545-6258
 Fax (800) 611-2323
 www.raychem.com

All information, including illustrations, is believed to be reliable. Users, however, should independently evaluate the suitability of each product for their application. Raychem makes no warranties as to the accuracy or completeness of the information, and disclaims any liability regarding its use. Raychem's only obligations are those in the Raychem Standard Terms and Conditions of Sale for this product, and in no case will Raychem be liable for any incidental, indirect, or consequential damages arising from the sale, resale, use, or misuse of the product. Specifications are subject to change without notice. In addition, Raychem reserves the right to make changes—without notification to Buyer—to materials or processing that do not affect compliance with any applicable specification.