

Nonlocating Multiple-Channel Alarm Module

Installation Instructions

H54831 PN839319

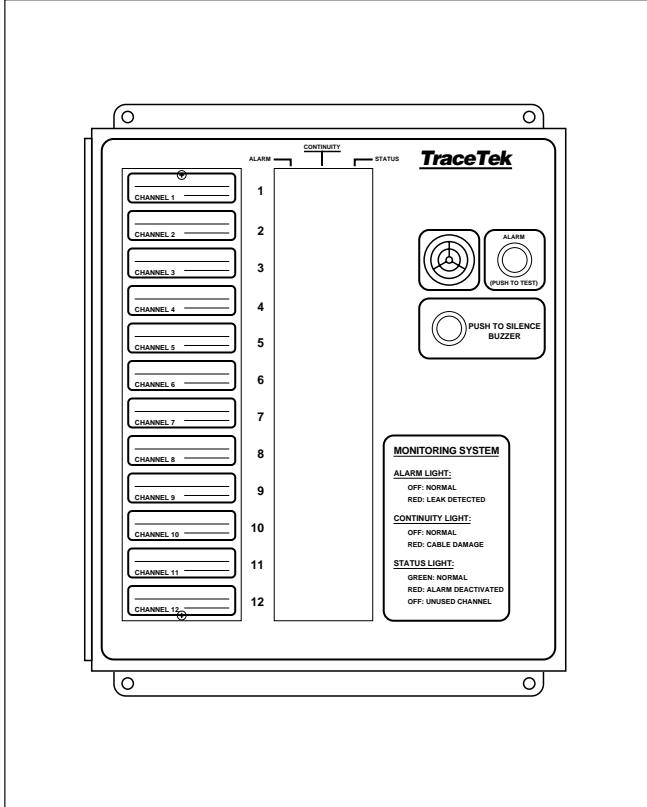

Description

The TTG Multiple-Channel Alarm Module with display options for 4 and 12-channels is used with TraceTek® sensing cable types TT1000, TT3000, TT501, and TT5000 to detect fluid leaks.

Module Location

The enclosure is rated NEMA 13. The ambient temperature of the module location must remain between 32° and 105°F (0° to 40°C).

Parts (supplied)

1 each Alarm module (TTG-x)
1 each TT-Sponge

Installation Materials/Tools (not supplied)

Wall fasteners for surface mounting (4 each)
Hole punches for electrical conduit

Electrical Codes

Installation must comply with relevant sections of the National Electrical Code including Article 504, "Intrinsically Safe Systems" and all other codes and regulations that apply.

Approvals



Hazardous Locations:
Class I, Div. 2, Groups A, B, C and D
For use with intrinsically safe sensor circuits for Class I, Div. 1, Groups A, B, C and D

Typical System

Note: Maximum sensor length on any channel is 50 feet.
Maximum jumper cable length on any channel is 3000 ft. (1000 m)

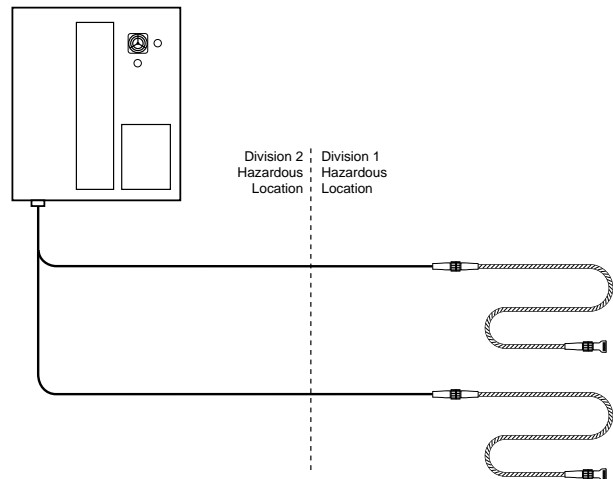

⚠ WARNING: This module is an electrical device which must be installed correctly to ensure proper operation and to prevent shock or fire. Read these important warnings and carefully follow all the installation instructions.

- Turn off power supply to panel before working inside panel.
- Intrinsic safety and approvals are based on the use of specified components only. Do not substitute components.

TTG Nonlocating Multiple-Channel Alarm Module Installation Instructions

Step 1. Mounting Procedure

1. Remove the four retaining screws located at the four corners of the circuit board.
2. Remove the circuit board and store in a dry, clean area until ready for installation.
3. Punch a hole on the lower right of the metal enclosure for power supply.
Note: There must be a 2-inch minimum distance between the power supply entry hole and the sensing cable entry hole.
4. Punch a hole on the lower left of the metal enclosure for sensing cable connection.
5. Mount for suitable wall fasteners and attach the metal enclosure.
6. Attach electrical conduit and replace circuit board.

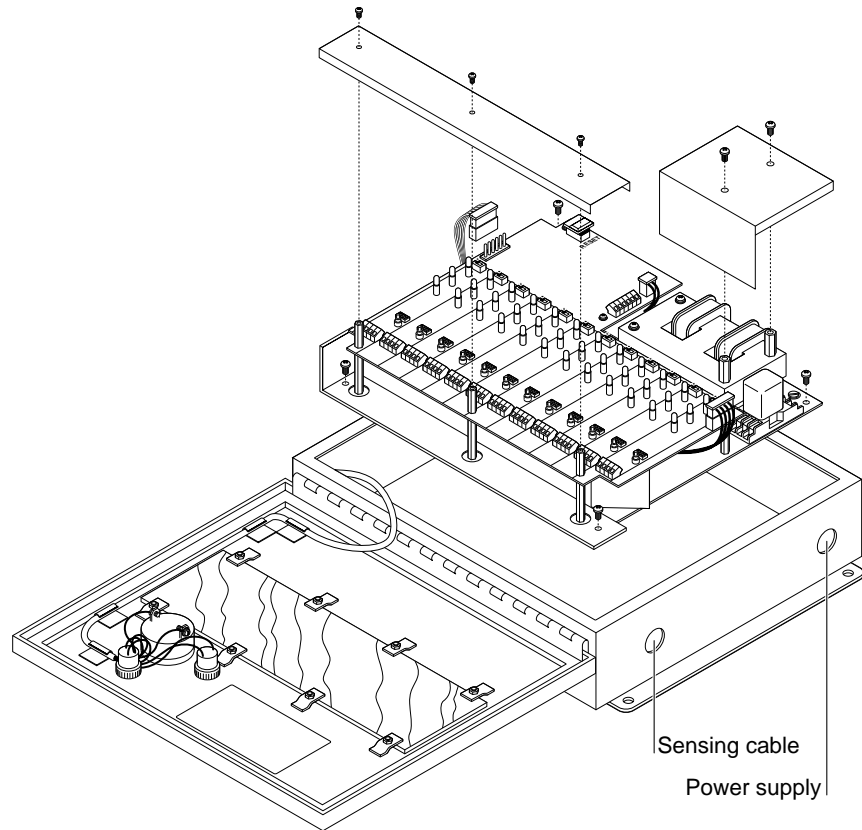

Step 2. Power Connection

(requires a dedicated 120/240-V ac circuit)

⚠ WARNING: Shock hazard. All wiring must be done with the power at breaker panel off.

1. Remove the transformer cover by removing the two screws that hold it in place.
2. Using wire nuts, make the power connection according to the tag attached to the transformer.
3. Connect the ground wire to the green ground screw (J) located next to the transformer.
4. Replace the transformer cover when finished.

Notes:

1. There is no main power switch or replaceable fuse in the alarm module. The transformer is fused internally.
2. Turning on module power before sensing cables are connected will result in an alarm condition.

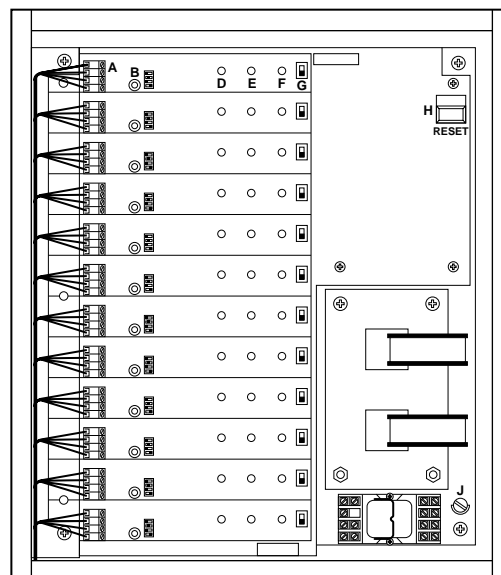

Step 3. Alarm Relay Connections

1. Connect the relay contacts.
Four circuits are provided each with a choice of normally open or normally closed potential free Form C contacts. These contacts are capable of switching 3 Amps at 120 V ac or 28 V dc.

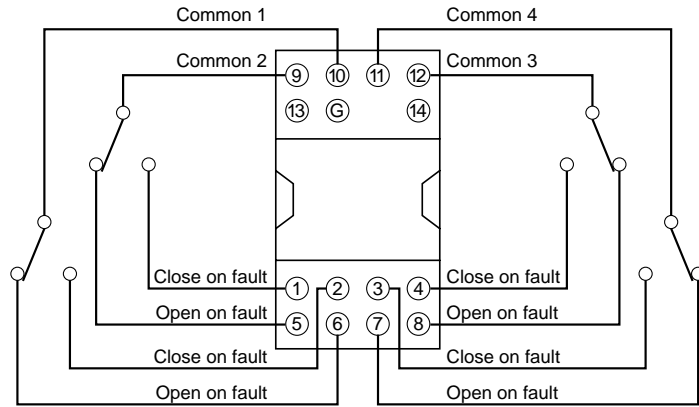

Step 4. Switch Settings

1. Two separate switches are provided that control the functions of each channel.
2. The DIP switch (labeled SW2) has four small switches used to power the channel and to match the alarm module voltage to the type of fluids being detected.
(Set L, M, and H according to the type of sensing cable connected to the channel. Set P in the ON position for operating channels, and in the OFF position for disabled channels.)
3. The STATUS switch (labeled SW3) is used to temporarily disconnect a channel from the alarm circuitry. Set SW3 switch to ON for all channels in use and to OFF for all unused channels. LED3 will change colors as SW3 is switched: **Green** - ON
Red - OFF

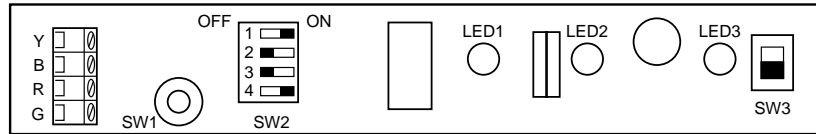

	OFF	ON	Hydrocarbons	Water/Aqueous Chemicals
L	1	L	ON	OFF
M	2	M	OFF	OFF
H	3	H	OFF	ON
P	4	P	ON	ON

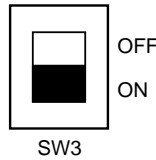

**TTG Nonlocating Multiple-Channel Alarm Module
Installation Instructions**

Step 5. Sensing Cable Installation

1. Remove the cover plate at the left of the circuit board by removing the three screws which hold it in place.
2. Strip back 1-1/2" of the outer jacket of the jumper cable and strip the ends of the wires to expose 1/4" of bare conductor. (*Be careful not to damage the insulation of the wires while stripping back the outer jacket.*)
3. Connect the wires of the jumper cable or leader cable to the terminal making sure that the color wires are connected to the same color terminal block (A).
4. Replace cover plate and tighten screws.

Note: To ensure intrinsic safety, do not install intrinsically safe sensing cable wire and power supply cables in the same conduit.

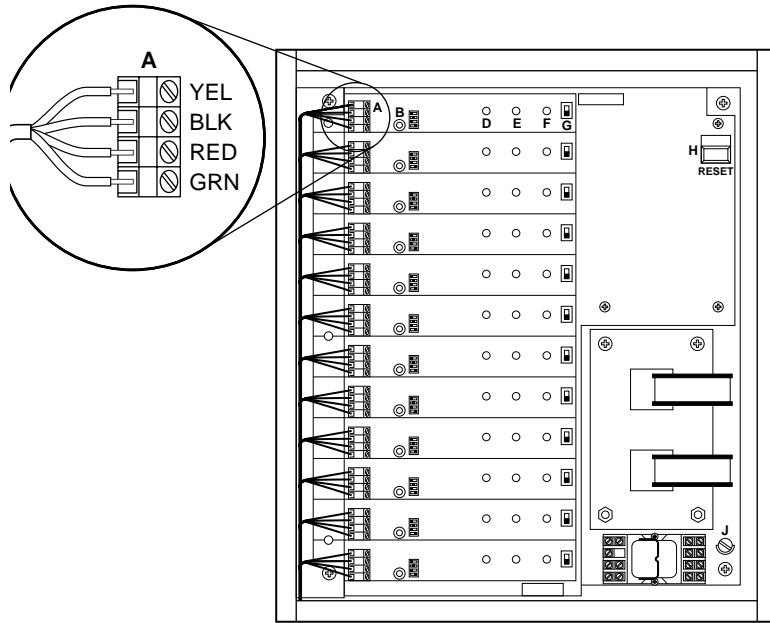

Step 6. Module Connection and System Testing

Testing the alarm module

1. Complete the wiring of all channels in use. Be sure all jumper cable, leader cable and sensing cable is connected.
2. Apply power to the alarm module.
3. All STATUS lights (F) of the channels being used should be green. If any are red, turn ON the SW3 (G) status switch.

If the alarm (D) or continuity lights (E) are on, check for miswiring, a missing sensing cable, or a tripped sensing cable.
4. Test each channel by pressing the TEST button (B) for fifteen seconds.

Module tests properly when:

- a. The red light (D) for that channel goes on immediately.
- b. The relay activates within fifteen seconds.
- c. The alarm sounds within fifteen seconds.
- d. The red light on the front door panel goes on within fifteen seconds.

Note: If the alarm module does not test properly, call your local TraceTek representative.

5. Press the RESET button (H) after **each** channel test.
6. Press the ALARM button on the front door panel to check that the alarm sounds and the red ALARM light on the button is illuminated.

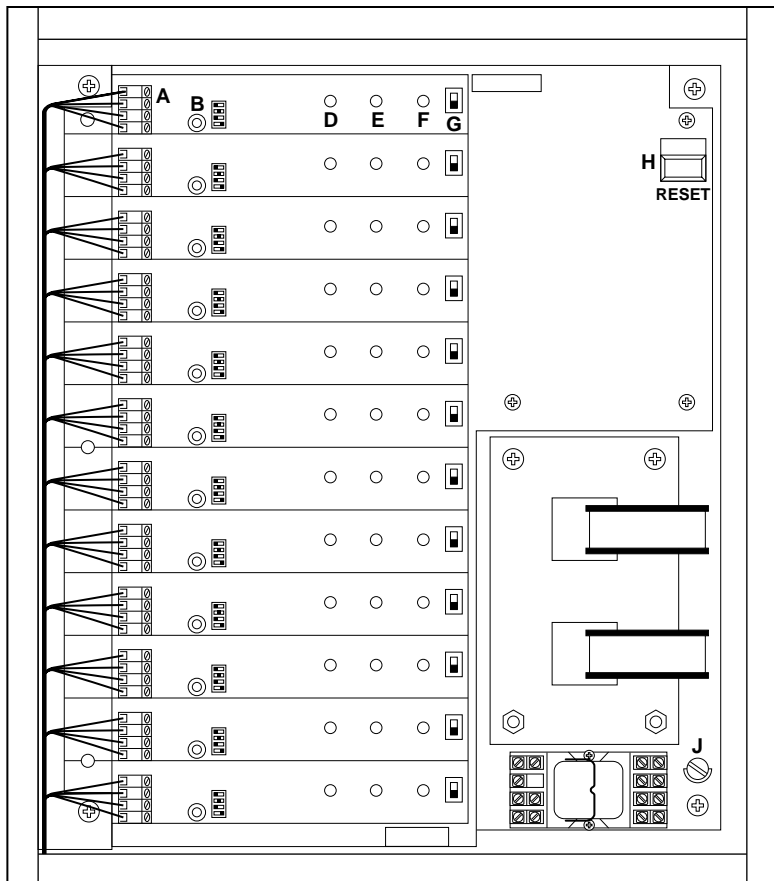

Step 6. Module Connection and System Testing (continued)

Testing the Sensing Cable(s)

TT1000 or TT3000 sensing cables:

1. Use the TT-sponge supplied to test the sensing cable. Depress the TT-sponge firmly onto the sensing cable and hold it for fifteen seconds.

System tests properly when:

- a. The red ALARM light (D) on the circuit board is illuminated.
 - b. The red ALARM light on the front door panel is illuminated.
 - c. The alarm sounds.
2. Press the SILENCE BUZZER button on the front door panel after alarm sounds.
 3. Remove the sponge and press the RESET button (H) at the end of each test.

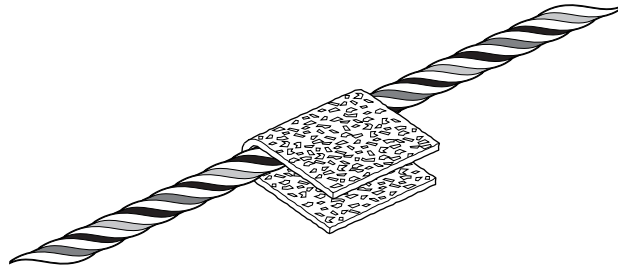

TT501 or TT5000 Sensing Cables:

1. Using a 3/8" pipe or tube, wrap the sensing cable around it and hold firmly for fifteen seconds. When finished, straighten out the cable.

System tests properly when:

- a. The red ALARM light (D) on the circuit board is illuminated.
 - b. The red ALARM light on the front door panel is illuminated.
 - c. The alarm sounds.
2. Press the SILENCE BUZZER button on the front door panel after alarm sounds.
 3. Press the RESET button (H) after each test.

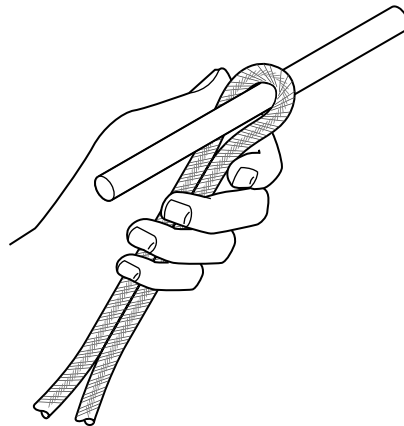

Step 7. Channel Identification

1. Clearly mark the front door panel to identify the location of each sensing cable as it is tested and installed.

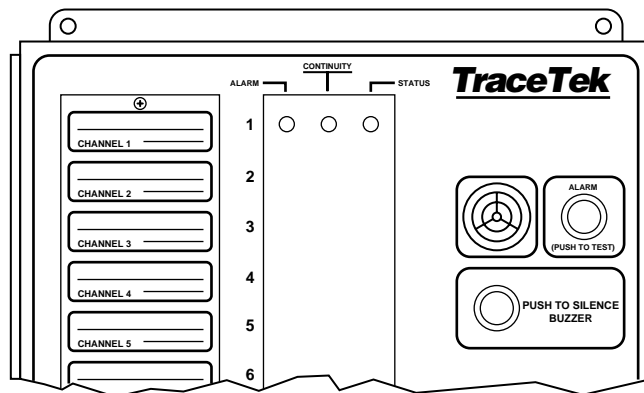

Raychem Corporation
Commercial & Industrial
Infrastructure Division
300 Constitution Drive
Menlo Park, CA 94025-1164
Tel (800) 545-6258
Fax (800) 611-2323
www.raychem.com

Raychem Corporation
2015 Spring Road
Suite 700
Oak Brook, IL 60521
Tel (708) 572-6300
Fax (708) 572-1469